

Solar PV and VPhase

Solar PV and VPhase voltage optimisation are two complementary technologies that can benefit from being installed alongside each other, reducing the overall payback period and improving the return on investment for the consumer.



The facts

- ➔ Solar PV installations currently have widespread appeal largely due to the generous Feed in Tariffs available.
- ➔ In the UK, there are nearly 2,000 MCS registered installers of solar PV systems.
- ➔ VPhase voltage optimisation devices can be installed alongside solar PV systems.
- ➔ With an electrician on site, the incremental time and cost of adding the VPhase is very low.
- ➔ Installing a VPhase with a solar PV system, reduces the payback period and improves the return on investment.
- ➔ Solar PV + VPhase = added value for the customer
- ➔ Solar PV and VPhase together result in a more energy efficient home



	Solar PV	Solar PV + VPhase
Cost	c. £10,000	c. £10,300
£ saving per annum	£895	£955
CO2 saving per annum	1,000kg	1,180kg
Annual Return on Investment	8.8%	9.4%

For MCS installers

Please contact one of our regional Sales Managers to discuss how you can scope the VPhase voltage optimisation device into your jobs.

We have an extensive network of distributors and wholesalers throughout the UK from which you can buy the VPhase device.

Our sales managers will also help advise about the features and benefits relating to the product and the joint benefits from combining the VPhase with a solar PV installation.

South East - Gordon Billings - 07738 424 856

South West - Adrian Fishley - 07810 523 369

North - Neil Morris - 07860 400 254

Head of Sales - Simon Hollidge - 07860 400 253



VPhase and Embedded Generation in a domestic or similar electrical installation.

Embedded Electricity Generation is becoming a more common occurrence in properties as part of an energy efficient and low carbon installation. Embedded generation can take many forms including:

- Solar Photovoltaic (PV)
- CHP (and micro CHP)
- Wind Power

Can VPhase be connected to a house containing embedded generation?

Yes, however simple rules should be observed:

Due to legislation (G83/1, BS EN 50438) the embedded generation must not supply power through a VPhase VX1 optimised circuit. I.e. do not plug embedded generation directly into a VPhase optimised socket outlet or fused spur. Always connect the embedded generation to an independent circuit at the consumer unit. Legislation requires that embedded generation must be automatically disconnected if the utility (supply) voltage rises above 264V. Therefore the embedded generation must not be connected directly to a VPhase optimised circuit. An example of a consumer unit containing embedded generation is given:

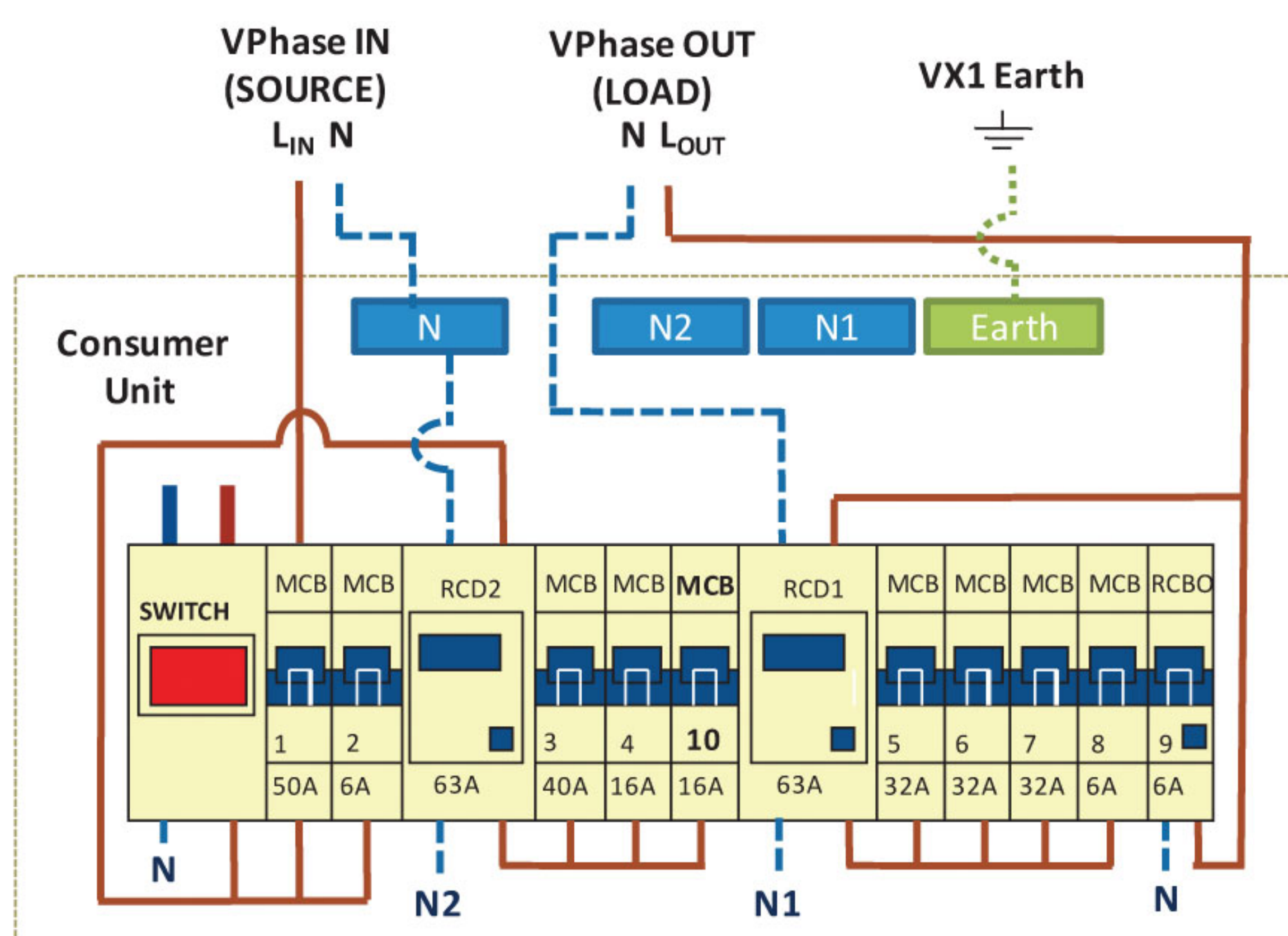

MCB	Circuit
N°1: 50A	VPhase supply
N°2: 6A	Fire alarm (not RCD protected)
RCD2 Protected ways (NOT supplied by VPhase)	
N°3: 40A	Electric shower
N°4: 16A	Electric immersion heater
N°10: 16A	Embedded Generation
RCD1 Protected ways (Voltage Optimised: Supplied by VPhase)	
N°5: 32A	Socket Ring Circuit
N°6: 32A	Socket Ring Circuit
N°7: 32A	Socket Ring Circuit
N°8: 6A	Lighting Circuit
RCBO Protected way (Voltage Optimised: Supplied by VPhase)	
N°9: 6A	Lighting Circuit (Separated from RCD1 to conform with wiring reg 314)

The embedded generation must not be directly connected to voltage optimised circuits 5 to 9. In this example an extra non-voltage optimised circuit has been included (Circuit 10) connected at RCD2 for the embedded generation.

Will the embedded generation continue to supply all of the electrical loads at the property?

Yes.

Loads on the VPhase supplied voltage optimised circuits will still be supplied with power from your embedded generation. Electric current will flow from your embedded generation through the VPhase and on to the Voltage optimised circuits. The current path will be as shown:

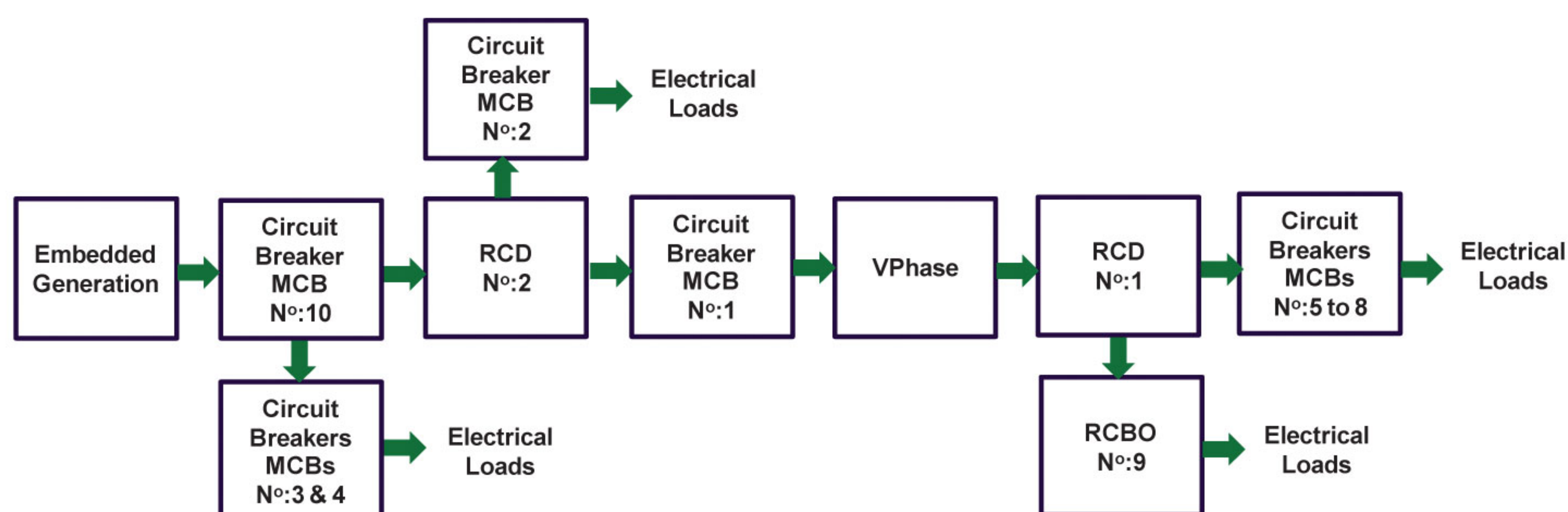

VPhase plc
Capenhurst Technology Park
Chester
CH1 6EH

T: 0845 003 8235
F: 0845 003 8269
E: info@vphase.co.uk
www.vphase.co.uk